

KENWOOD

PORTABLE COMPACT DISC PLAYER

# DPC-72

---

## INSTRUCTION MANUAL

KENWOOD CORPORATION



**Keep this manual handy for future reference.**

### **For your records**

Record the serial number, found on the bottom of the unit, in the spaces designated on the warranty card, and in the space provided below. Refer to the model and serial numbers whenever you call upon your dealer for information or service on this product.

Model DPC-72 Serial number \_\_\_\_\_

## Unpacking

Unpack the unit carefully and make sure that all accessories and cables are put aside so they will not be lost.

Examine the unit for any possibility of shipping damage. If your unit is damaged or fails to operate, notify your dealer immediately. If your unit was shipped to you directly, notify the shipping company without delay. Only the consignee (the person or company receiving the unit) can file a claim against the carrier for shipping damage.

We recommend that you retain the original carton and packing materials for use should you transport or ship the unit in the future.

**CAUTION:** Use of controls or adjustments or performance of procedures other than those specified herein may result in hazardous radiation exposure.

In compliance with Federal Regulations, following are reproductions of labels on, or inside the product relating to laser product safety.

Location: Bottom panel

<b>CAUTION AGAINST HIGH TEMPERATURE</b> DO NOT LEAVE THIS CD PLAYER IN A PLACE SUBJECT TO HIGH TEMPERATURE, SUCH AS IN DIRECT SUNLIGHT, IN A CAR WITH THE WINDOWS CLOSED OR NEAR A HEATER. (EXCESSIVELY HIGH TEMPERATURE MAY CAUSE A CHANGE OF SHAPE, COLOR OR MALFUNCTION.)	<b>ATTENTION A LA HAUTE TEMPERATURE</b> NE PAS LAISSER CE LECTEUR-CD DANS UN ENDROIT SUJET A HAUTE TEMPERATURE, COMME SOUS LES RAYONS DIRECTS DU SOLEIL, DANS UNE VOITURE AUX FENETRES FERMEES, OU PRES D'UNE SOURCE DE CHALEUR. (UNE TEMPERATURE EXTREMEMENT HAUTE PEUT DEFORMER, DECOLORER L'APPAREIL, OU EN CAUSER DES FONCTIONNEMENTS DEFECTUEUX.)
--	--

CERTIFIED ONLY TO CANADIAN ELECTRICAL CODE

CERTIFIÉ EN VERTU DU CODE CANADIEN DE L'ÉLECTRICITÉ SEULEMENT

### PRECAUTION

NE PAS UTILISER LES ADAPTATEURS DE COURANT ALTERNATIF, OU LES ADAPTATEURS DE BATTERIE D'AUTOMOBILE, QUI NE SOIENT DE NOTRE DESIGNATION.

**KENWOOD**  
PORTABLE COMPACT  
DISC PLAYER  
DPC-72

MANUFACTURED  
SEPTEMBER 1990  
SERIAL NO. KC

DC 7.5V  
(EXCLUSIVE AC ADAPTOR) +  
DC 6V(LR6), AA\*, AM3X4

KENWOOD CORPORATION  
2-17-5 SIBUYA, SIBUYA-KU  
TOKYO 150, JAPAN  
MADE IN JAPAN

KENWOOD CERTIFIES THAT THIS EQUIPMENT CONFORMS TO DHS REGULATIONS 21 CFR CHAPTER I SUBCHAPTER J.

Location: Inside, surface of disc lid.



**CAUTION: INVISIBLE LASER RADIATION WHEN OPEN AND INTERLOCKS DEFEATED. AVOID EXPOSURE TO BEAM.**  
**ATTENTION: RAYON LASER À L'OUVERTURE ET À L'INHIBITION DU VERROUILLAGE. ÉVITER TOUTE EXPOSITION AU FAISCEAU!**  
**VORSICHT: UNSICHTBARE LASERSTRAHLUNG TRITTS AUS WENN DECKEL GEDÖFFNET UND WENN SICHERHEITSVERRIEGELUNG ÜBERBRÜCKT IST. NICHT DEM STRAHL AUSSETZEN.**

## Before applying power of AC adaptor

### Important!

#### USA, Canada, U.K., Europe and Australia

Unit shipped to the above are not equipped with an AC voltage selector switch and the discussion of such a switch that follows should be disregarded.

#### All other countries

AC adaptor shipped to countries other than the above are equipped with an AC voltage selector switch on the bottom cover. Refer to the following paragraph for the proper setting of this switch.

## AC voltage selection

AC adaptor operates on 110~120 volts or 220~240 volts AC. Before connecting the power cord to your AC outlet, make sure that the setting position of this switch matches your line voltage. If not, it must be set to your voltage in accordance with the following direction.

### Note:

Our warranty does not cover damage caused by excessive line voltage due to improper setting of the AC voltage selector switch.

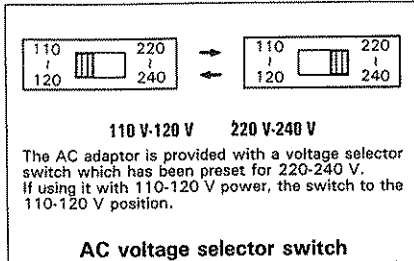
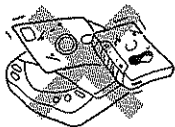

Fig. 1

## WARNING:

TO PREVENT FIRE OR ELECTRIC SHOCK, DO NOT EXPOSE THIS APPLIANCE TO RAIN OR MOISTURE.

## Precautions for use



- This unit uses a magnet. Do not place a floppy disk, cassette tape, etc. on the unit.

To maintain the high performance and reliability of this unit, avoid using or storing it in the following conditions.



- Dusty places.

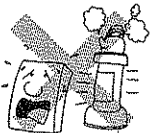

- Near heat sources such as stoves, etc.

## For United Kingdom

The mains plug must be removed from the wall socket prior to any internal examination.

### Important

The wires in this mains lead are coloured in accordance with the following code:

Blue ..... Neutral  
Brown ..... Live

The wires in this mains lead must be connected to the terminals in the plug as follows:

**Wire colour**                      **Plug terminal marking**  
Blue ..... N or Black  
Brown ..... L or Red

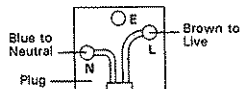

### Notes:

- 1) If a 13-amp plug is used, this must be fitted with a 5-amp fuse.
- 2) If a 3-pin plug with earthing contact is used, no wire must be connected to the E terminal.

## WARNING NOTICE:

IN MOST CASES IT IS AN INFRINGEMENT OF COPYRIGHT TO MAKE COPIES OF TAPES OR DISCS WITHOUT THE PERMISSION OF THE COPYRIGHT OWNERS. ANYONE WISHING TO COPY COMMERCIALY AVAILABLE TAPES OR DISCS SHOULD CONTACT THE MECHANICAL COPYRIGHT PROTECTION SOCIETY LIMITED OR THE PERFORMING RIGHTS SOCIETY LIMITED.

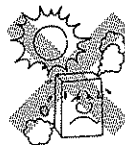

- Places exposed to direct sunlight, especially in a closed car.



- Extremely cold places.

## ■ Condensation (dew)

- When the unit is placed in a humid place or just after heater is turned on, condensation may form inside the unit and unit may not function correctly. At that time, press the [ ■ ] (STOP) button twice to turn off the unit (when the button is pressed once, the unit only enters stop mode), leave the unit for about 1 hour, then load a disc and start play.

## ■ Using headphones

- CD players have such a low noise level that listeners often tend to overly increase the sound volume. Set the sound volume to an appropriate level to protect your ears from excessive shock.
- For your safety and the safety of others, do not use headphones while driving a car or other type of vehicle.
- Be careful not to fall asleep while listening to music using headphones.
- Continuous use of headphones for long periods may hurt your ears.

Fig. 1

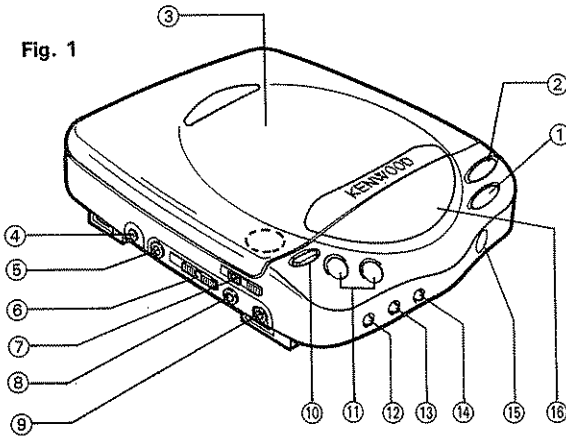

Right side

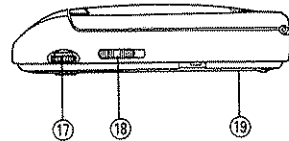

Fig. 2

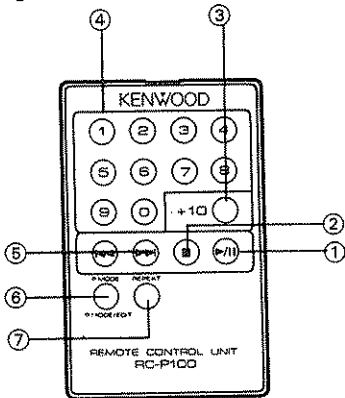
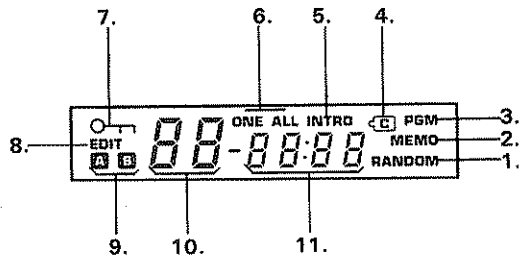

Fig. 3



## Controls, connectors and indicators <Fig. 1>

- |  |                                     |
|--|-------------------------------------|
| ① [▶  ] PLAY/PAUSE/ON button (POWER ON)* | ⑪ [◀◀ ▶▶] SKIP/SEARCH button*       |
| ② [■] STOP/OFF button (POWER OFF)*       | ⑫ REPEAT button                     |
| ③ Lid                                    | ⑬ P.MODE (Program mode)/EDIT button |
| ④ DC IN jack                             | ⑭ CHARGE button                     |
| ⑤ DIGITAL OUT jack                       | ⑮ Remote control receptor           |
| ⑥ SP switch                              | ⑯ Display*                          |
| ⑦ Lid Lock knob                          | ⑰ VOLUME knob                       |
| ⑧ LINE OUT jack                          | ⑱ HOLD/LAST MEMO. (memory) switch   |
| ⑨ PHONES jack                            | ⑲ Battery cover                     |
| ⑩ OPEN button                            |                                     |

\* While the AC adaptor or car battery adaptor is being used, the lamp on the [▶||], [◀◀], [▶▶], [■] button and display is lit up for easy recognition.

## Wireless Remote Controller <Fig. 2>

The function of each switch is the same as that of the switches on the main unit.  
**POWER ON operation is not possible with the remote controller.**

- ① PLAY/PAUSE button [▶||]
- ② STOP button [■]
- ③ Direct Music Selection button (+ 10) (Remote Controller only)
- ④ Direct Music Selection button (0 - 9) (Remote Controller only)
- ⑤ Skip/Search button [◀◀ ▶▶]
- ⑥ P.MODE (Program mode)/EDIT button
- ⑦ REPEAT button

## Display description <Fig. 3>

- |  |   |
|--|---|
| 1. RANDOM play mode indicator          | 8. EDIT mode indicator  |
| 2. MEMO (Last track memory) indicator  | 9. This is indicated either Side A or B of the tape while [EDIT] is set |
| 3. PGM (Program mode) indicator        | 10. Track number display  |
| 4. CHARGE indicator                    | 11. Elapsed time display  |
| 5. INTRO (Introduction play) indicator |   |
| 6. Repeat mode indicator               |   |
| 7. HOLD indicator                      |   |

## Power source

■ Use in the following method:

Household AC Power Source	Use the provided AC adaptor.
Alkaline dry Battery	Use size AA alkaline dry batteries which are available in the general market.
Rechargeable Battery (Provided)	Charge with the provided AC adaptor before use.
Car Battery	Use the optional car-battery adaptor DC-C6 (exclusive for 12-V car).

## ■ How to use the main unit with the provided AC adaptor <Fig. 4>

- When this provided AC adaptor is used, the power source can be supplied from household outlets. Insert the plug of the AC adaptor into the power-source terminal, then connect the AC power adaptor to a household outlet.
- Pull out the AC adaptor from the outlet when it is not in use. Conduct insertion into or pulling out from the power source terminal after pressing the STOP [ ■ ] button twice in order to turn the main unit into "POWER OFF" condition.

Fig. 4

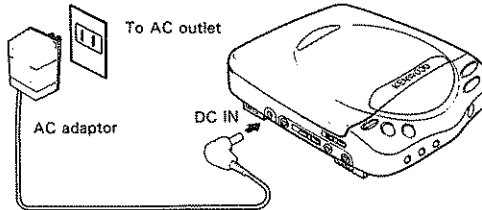

## ■ How to use the unit with the provided rechargeable batteries or alkaline dry batteries

The usable batteries are only the provided rechargeable batteries.  
Generally marketed rechargeable batteries and manganese dry batteries cannot be used.

### ● How to Insert the batteries into the battery compartment <Fig. 5>

① **Open the battery cover.**

② **Insert the batteries.**

Insert the four provided rechargeable batteries or alkaline dry batteries into the battery compartment surely by paying attention for correct polarity.

③ **Close the battery cover.**

Fit the hook of battery cover into the specified position.

Be sure to fit it into the specified position until it clicks and gets locked.

**Charge the provided rechargeable batteries for 6 hours, if you use them for the first time.**

Fig. 5

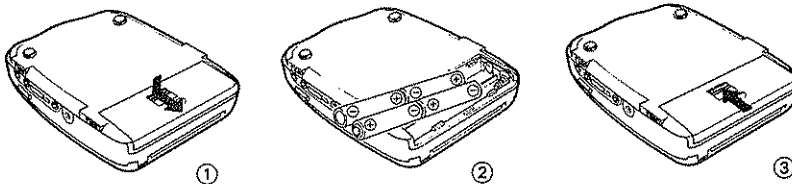

● **How to Recharge <Fig. 6>**

Turn the Power off and insert provided rechargeable batteries into the battery compartment, then connect an AC adaptor to the main unit before pressing CHARGE button in order to start recharging. (Recharging cannot be conducted when Power is turned ON)

During recharging, the  mark blinks slowly.

Recharging is canceled automatically by the built-in and 6-hour timer when recharging is completed.

1. Recharging will be canceled when PLAY/PAUSE [▶||] button or STOP [■] button is pressed during recharging. Other operations cannot be conducted.
2. The CHARGE button do not functions when the HOLD switch is turned ON.
3. Recharging is canceled when the AC-adaptor plug is pulled out an outlet while recharging is being conducted, or when power supply is cut.

Fig. 6

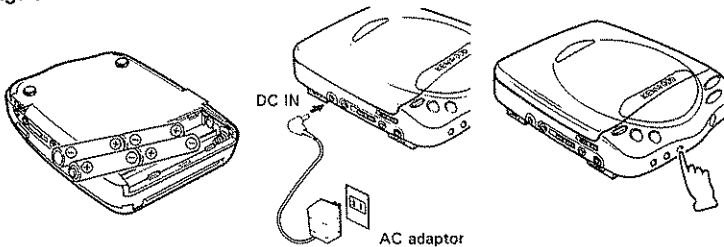

● **How to Recognize the Recharging Time**

In the normal use, 5 hours of recharging allows continuous play for about 2 hours.

**Recharge them for about 6 hours, however, if they are not used for a long period of time.**

● **How to make batteries stand up to long use**

If recharge is repeated for the provided batteries, where as the power of batteries is still remained, the batteries may not be recharged enough as their property. In such a case, use up the power of them before conducting recharging, which allows them for normal recharging.

● **Service Life of Rechargeable Battery**

Rechargeable battery has a life.

After about 500 times of recharging, its performance (operating time) is halved as compared to a new battery. If operating time shortens considerably although you have charged your battery properly, four rechargeable batteries for replacement.

**Cautions:**

- Do not recharge the manganese or alkaline dry batteries.
- Be sure to use only the provided AC adaptor for recharging. It is dangerous if you use other kind of AC adaptor.
- Avoid adverse recharging or short circuit. They result in causing of such troubles as deterioration of rechargeable batteries and generation of heat.
- Do not disassemble or modify it by yourself.
- Do not touch the CD player or AC adaptor with wet hands.

## Listening through headphones <Fig. 7>

- Connect the headphone plug with the "PHONES" jack. Conduct the pull-in/out operation of the jack during Power is OFF.
- Adjust the volume with the VOLUME control.

### Notes:

- Keep the plug of headphone clean all the time. Non-clean plug may cause noise.
- Avoid using the headphone when you drive a car and so on for traffic safety.
- Be careful not to fall asleep with the headphone on.

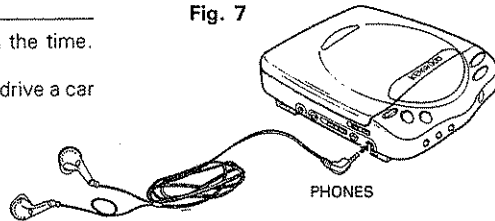

Fig. 7

As a Compact Disc contains very little noise, a sudden loud sound could be output if the VOLUME control is adjusted too high: this could cause serious damage to your ears.

## Playback through a home audio system (analog input)

### ■ Playback using the "LINE OUT" output <Fig. 8>

- Using the provided audio connection cord, connect the 3-pin miniplug to "LINE OUT" terminal of this unit.  
Connect the other end of the cord to the amplifier's external input jacks (AUX jacks, TAPE PLAY jacks, etc.).  
Connect the red plug to the "R" (right channel) input jack and the white plug to the "L" (left channel) input jack.
- Adjust the sound volume using the amplifier's volume control.
- When the direct input from the main unit to a tape deck is to be made, adjust the volume with volume-level adjuster (REC LEVEL) of the tape deck.

### Caution:

- Before making connections, be sure to turn the amplifier power off.

Do not connect the main unit to the PHONO terminal of the amplifier.

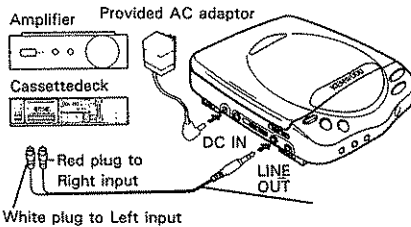

Fig. 8

## Playback through a home audio system (COAXIAL digital input)

- Using a digital connection cord optionally available in audio stores, connect the DIGITAL OUT jack of this unit with an amplifier equipped with a coaxial digital input jack.
- Adjust the sound volume using the amplifier's volume control.

### Caution:

- Before making connections, be sure to turn the amplifier power off.

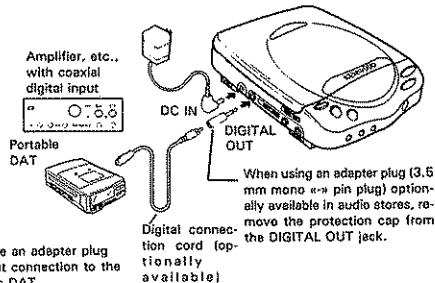

- Also use an adapter plug for input connection to the portable DAT.



## CD playback in an automobile <Fig. 9>

### ■ Use in the car audio cassette adaptor CAC-1

- When the power source is taken from a cigar socket of a car, use the car battery adaptor DC-C6. It allows you to enjoy listening to music for a long time without worrying about the battery consumption.
- Insert the plug of car audio cassette adaptor CAC-1 into the "LINE OUT" terminal of the main unit. Insert the CAC-1 to the car component deck, and turn the car component deck into the PLAY mode.
- Adjust the sound volume using the volume control of the car stereo.

#### Notes:

- **Since car battery adaptors available in the market have different polarity and voltage, they may result in troubles.**  
(Be sure not to use a car battery adaptor other than the DC-C6.)
- In case the unit is used in a car, install it taking the safety in consideration, so that it does not interfere with the driving operations.
- The CAC-1 cannot be used with some car audio cassette models.
- Do not leave the unit in a closed automobile where the temperature is expected to be high.
- Place the unit on a soft place where automobile vibrations are not easily transmitted.
- If any sound skipping occurs due to vibrations, turn on the [HOLD] switch to reduce the sound skipping.

Fig. 9

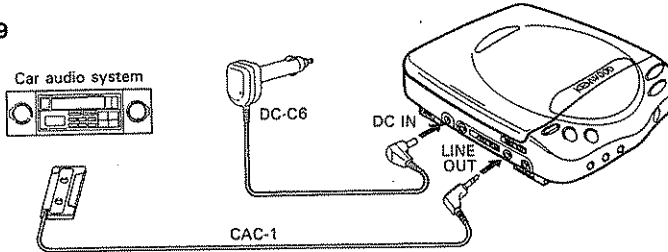

- \* The DC-C6 Car Battery Adaptor is an optional accessory with the USA, Canada, UK and Europe type models.
- \* The CAC-1 Audio Cassette Adaptor is an optional accessory with the UK and Europe type models.

## 8 cm CD single can also be played

This unit can play 8 cm CD singles directly without using an adaptor.

#### Caution:

- Do not use an adaptor sold for other models (otherwise the CD or this unit may be damaged).

# How to play (Manual play)

## Manual Play (Basic Operation)

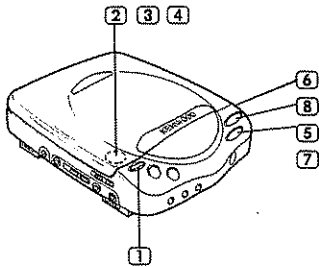

Leave the HOLD/LAST MEMO switch turned OFF.

- ① Push the OPEN button.
- ② Open the lid: Lightly lift the lid near the OPEN button.
- ③ Insert the disk: Be sure to keep the label side of the disk upward.
- ④ Close the lid.
- ⑤ Push the PLAY/PAUSE [▶ II] button:  
The unit starts playing automatically after scanning the data of the disk.
- ⑥ Adjust the volume.

When PLAY/PAUSE [▶ II] button is pressed to POWER ON.

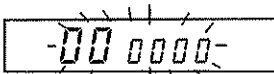

Blink

When the unit starts playing automatically.

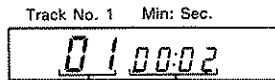

Track being played

Elapsed playing time

In the event that data is not read or a disc is not inserted. (It will turn out to be POWER OFF after elapsing of three minutes.)

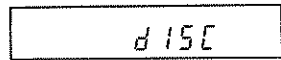

### PLAY MODE

Track No. 1 Min: Sec.



Track being played

Playback time blinks here.

### STOP MODE

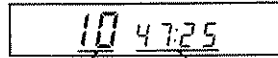

Total number of tracks

Total playing time

## To operate temporary stop (pause)

- ⑦ Push PLAY/PAUSE [▶ II] button:  
If you press it once more, the unit starts playing from the paused position.

## To stop

- ⑧ Push the STOP [■] button:
  - If the STOP [■] button is pressed once, the unit is put in the stop mode. If it is pressed once again, the unit is turned out to be POWER OFF.
  - If the stop mode lasts for 3 minutes or more, the unit is turned out to be POWER OFF.

### Notes:

- If the HOLD switch is being turned ON, PLAY/PAUSE [▶ II] operation cannot be activated even the button is pressed.
- If OPEN button is pressed, all the contents is erased and the unit is turned out to be POWER OFF.
- If the lid is open, all the functions do not work. Closing the lid does not simply allow the unit to turn out to be POWER ON.
- If the PLAY/PAUSE [▶ II] button is pressed during the stop mode, the unit starts playing from the first track.
- When the music is played until the final track and the player has naturally entered the STOP Mode, it indicates the total playing time.
- Be sure not insert the disk up side down. If the disk is inserted into the unit with reverse side up, the unit can not start playing.
- Do not insert anything other than the disk into the disk tray.
- A disk may be damaged if it is inserted diagonally into the disk tray.

■ **To skip to the beginning of desired track (Skip feature, ◀◀, ▶▶), to search in the forward or backward direction (Search feature, ◀◀, ▶▶)**

- The skip function is activated with one press of button and the search function is activated with continuous press of button.
- Operate during play (Basic Operations (5), (6)), or stop mode (Basic Operation (8)).

(9) **To skip to the beginning of the track being played:**

Tap the ◀◀ button for an instant.

**To skip to the beginning of the next track:**

Tap the ▶▶ button for an instant.

- When you wish to skip back to the previous music, press the ◀◀ button once more.
- The first music is caused to play if ▶▶ button is pressed while the last music is being played.
- If you press ◀◀ button during the stop mode, the last music is activated to play.

(10) **How to operate the quick return with the main unit:**

Push ◀◀ button continuously.

**How to operate the quick traverse:**

Push ▶▶ button continuously.

- If you release the quick return and quick traverse buttons, the unit plays the music from that position.
- If an operation is made during the pause mode, the music is paused at the position where the button is released.

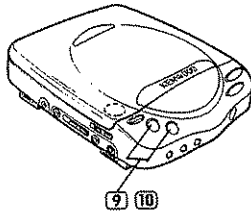

## How to Play (Direct Play)

### ■ Direct Play

- **This function can be operated only by the remote controller. (RC-P100)**
- By just pressing the direct music selection button, the selected music is played immediately.
- Operation can be performed during the play or stop mode (when the unit is stopped with a disc inserted).
- If the number larger than the number of musics in the disk is selected, it is not accepted.

(11) **In case of selecting either one of Musics 1 through 9:**

Push either of Buttons 1 through 9.

**In case of selecting either one of Musics 10 through 19:**

Push either one of Buttons 0 through 9 after pressing the +10 Button.

**In case of selecting either one of Musics 20 and beyond:**

Push either one of Buttons 0 through 9 after pressing the +10 Button twice.

**In case of selecting either one of Musics 30 and beyond:**

Push either one of Buttons 0 through 9 after pressing the +10 Button three times.

# How to play (Repeat play)

## Repeat play

- If the REPEAT button on the main unit is pressed during play or stop mode (basic-operation **8**), repeat play will be activated.

Every time the button is pressed

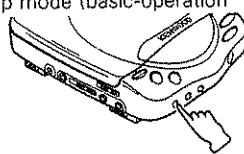

**REPEAT-one** ..... Repeatedly plays the music played or selected.

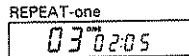

**REPEAT-all** ..... Repeatedly plays all the musics or all the programmed (reserved) musics in the disk.

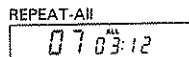

**RANDOM PLAY** ..... The CD player selects tracks in a random order among all tracks on a disc or all tracks in a program.

During random track search

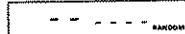

Track Nos. light in order.

During Random play

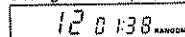

- When the Random mode is initiated in the middle of play, the random track search starts with the next track to the track being played.
- When forward skip or fast forward is initiated by pressing the [▶▶]/FF button during Random play, random track search starts.
- When backward skip or fast reverse is initiated by pressing the [◀◀]/REV button during Random play, random track search starts from the beginning of the track being played.
- Random play continues until the [■] button is pressed or the REPEAT button is pressed to cancel it.
- The direct music selection buttons on the remote control unit cannot be used during Random play.

**INTRO PLAY** ..... The first 15 seconds of every track on a disc is played in sequence. This function is convenient for checking the tunes recorded on a disc.

INTRO PLAY

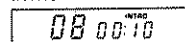

**Cancellation of REPEAT play** ..... It turns off the indication of REPEAT.

- When the Intro mode is set in the stop mode and the play is started, Intro play starts from track No. 1.
- When the Intro mode is initiated in the middle of play, Intro play starts with the next track to the track being played.
- When the [▶▶] button is pressed during Intro play, the track being played is skipped and intro play of the next track starts.
- When the [◀◀] button is pressed during Intro play, Intro play restarts from the track being played.
- Intro play continues until the [■] button is pressed or the REPEAT button is pressed to cancel it.

**How to Stop Play**  
Press the STOP [■] button on the main unit.

## How to Play (Program Play)

- Operate during the stop mode (Basic operation (8)). It cannot be operated if the mode is in other than the stop mode.
- 24 favorite musics can be programmed (reserved) in the order you like to listen to.
- After completion of the programming (reservation), play is activated if "PLAY/PAUSE [▶||]" is pressed.

### ■ How to Program with Direct Music Selection (Remote controller only)

(Basic Operations 1 - 6 are omitted.)

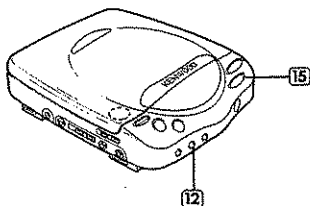

- 12 Push P. MODE button:**
- It enters the program input mode.

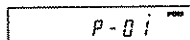

- 13 Select the track (music):**  
(Select the music with the direct music selection button on the remote controller. Follow the procedures in (11).)  
Reservation is completed by selecting the music.
- Completion of reservation of Music 1 (P-01).

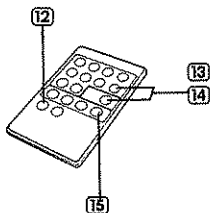
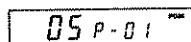

- 14 Select the track (music) (from Program number 2, 3, ... 24):**
- Repeat the operation in (13). By repeating music selection, the reservation can be made one after another.

- 15 Push PLAY/PAUSE [▶||] button:** starts to play.
- Operate with the HOLD/LAST MEMO. switch in the OFF condition.

### ■ How to program with the SKIP button

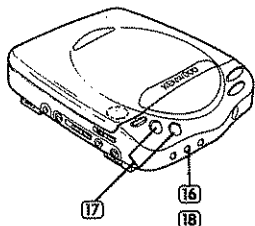

- 16 Push P. MODE button:**
- Enters the program input mode (the same operation as in (12)).
  - Also operate with the P.MODE button on the remote controller.

- 17 Select with the Skip/Search [◀◀ ▶▶] button (Program number 1):**

- 18 Push the P. MODE button.**

- 19 Select the music (from Program 2, 3, ... 24):**
- Repeat the operation in (17) and (18).

- The maximum number of input tracks for program is 24. The following indication is shown after those 24 tracks are input.

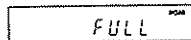

- During the programmed play, the unit is in the auto space mode. Then, the four-second pause is inserted between the tracks.
- If the skip [◀◀ ▶▶] button is pressed during the programmed play, skip search can be made only with the programmed track.
- When the program is called during the program standby mode and the PLAY/PAUSE [▶||] button is pressed with HOLD/LAST MEMO. OFF (See Page 16), the player will play from the first track programmed, not the track whose number is indicated now.

## Intro program entry

This function allows to program only desired tracks while listening to the beginning of every track by Intro play (refer to page 13).

- The direct music selection buttons on the remote control unit cannot be used.

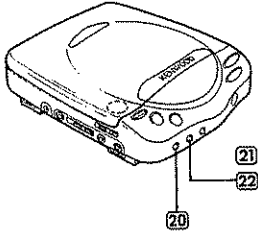

- ⑳ Push the REPEAT button Four times.

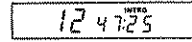

- ㉑ Push the P.MODE/EDIT button start the INTRO play

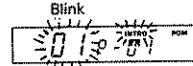

- ㉒ When a track you want to program is played, press the P.MODE/EDIT button.

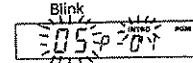

- During Intro program entry, the ►► and ◀◀ buttons can be used to skip tracks as required.
- The search function (FF/REV) and the pause function do not work during Intro program entry.

## Confirmation of the programmed contents

- This function can be operated when the disc is programmed and stopped.

- ㉓ Push the P.MODE button:

- Indicates the Program number 1.

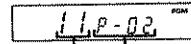

Track programmed Program No.

- ㉔ If the P. MODE button is pressed repeatedly:

- Then the programmed contents are indicated in order.
- If the music orders are indicated until the last programmed track, the indication returns to Program number 1.

## How to cancel all the programs

- ㉕ Put the unit to POWER OFF or open the lid:

- Push the STOP [■] button once, when the music is programmed and the disc is stopped in order to enter the unit into the stop mode, or press the STOP [■] button twice during play in order to put the unit to POWER OFF.

## How to change the contents of the program

- ㉖ Call the program number to be changed by pressing the P. MODE button:

Example:

When you wish to change the music in Track 11 of the Program Number 2 to Track 8, call the Program Number 2 by pressing the P. MODE/EDIT button.

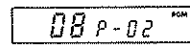
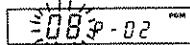
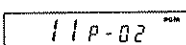

- You can also revise the track after indicating the Track 8 with ◀◀ and ►► buttons on the main unit, and then pressing the P. MODE/EDIT button.

## EDIT Function

EDIT function is the function to edit by fully making use of the recordable time of a tape when a CD is dubbed into a tape.

- In the stop mode, you can select EDIT modes by pressing the P.MODE/EDIT button twice.

**27 Push the P.MODE/EDIT button twice:**

- In the program stand-by mode, this operation can not be made.

**28 Input the accommodating time of the tape with the direct music selection buttons (0 - 9) and (+ 10). It is also possible set the digit of 10 by pressing the ►► button and the digit of 1 by pressing the ◄◄ button.**

**29 Push the P.MODE/EDIT button.**

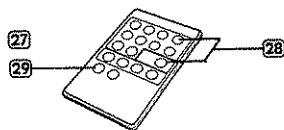
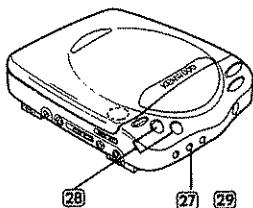

- Each tracks to be recorded is assigned automatically to side **A** or side **B** of tape, and the following displays appear.

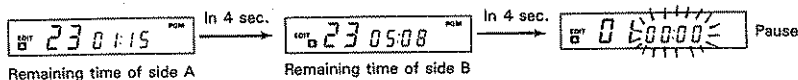

- Arrange the musics from the initial music of a CD in order so as to accommodate them within the designated accommodating time of Side A of a cassette tape, and select the most suitable music within its remaining time for the last music.
- Arrange the musics in order for Side B excluding the musics programmed into Side A, and select the most suitable music for the last music on Side B.
- When all the musics are recorded into Side A, "no-FILE" is indicated on the display and pause is activated at the first music on Side A.
- After Side A is completed, pause will be activated at the beginning part of Side B.
- When the playing operation is completed up to the end of Side B, the normal stop mode is automatically activated.

## Convenient functions

### ■ Prevention of misoperation [HOLD]/Reduction of sound skip [Anti shock]/Last memory function

- This unit has the HOLD function to prevent misoperation, the anti-shock function to reduce the sound skipping and the LAST MEMO. function to memorize the musics until the power is turned off. When the unit is used in the car or elsewhere where there is big vibrations, the sound skipping is reduced.

#### Turn on the HOLD switch:

- If the "HOLD" is turned on in the POWER OFF mode, the unit will not be turned to the POWER ON mode even though the PLAY/PAUSE [▶||] button is pressed.
- If the "HOLD" is turned on during the play, the button switches other than the "OPEN" button can not be operated.
- This operation can also be carried out with the remote control unit.

#### When the LAST MEMO. switch is turned on, the following operations are made:

- When the power is turned on from the off condition, the player starts to play the track from the beginning part of the track where the present location of the pick-up is read.
- If the STOP [■] button is pressed and the PLAY/PAUSE [▶||] button is pressed again, the player starts to play from the beginning part of the stopped track. (When it is paused at the near end of a track, it may start playing from the beginning part of the following track.)
- If the SKIP button [◀◀] is pressed during the stop mode, the player starts to play the track previous to the track for which the STOP [■] button is pressed.
- If the SKIP button [▶▶] is pressed during the stop mode, the player starts to play the track next to the track for which the STOP [■] button is pressed.
- The Last track memory function also work even in the Hold ON status.

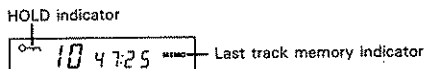

## SP switch

This unit incorporates the SP (Sound Processor) circuit to allow sound enjoyment with a wider range of tone. The SP circuit has been preset for a certain music category, but the setting can be changed according to your taste. SP switch position

1. Suitable for easy listening of fusion, etc.
2. Suitable for powerful music, such as rock.
3. Enhances the range of vocals.

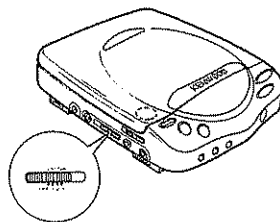



## Simple care and maintenance <Fig. 10>

### ■ Cleaning the cabinet

When the cabinet gets dirty, wipe it with a dry cloth. If the stain is so serious that it cannot be removed with a dry cloth, moisten the cloth with a small amount of water. After wiping with the moistened cloth, do not forget to remove the moisture with a dry cloth.

### ■ Cleaning the lens

Clean the lens carefully, using a commercially-available camera lens blower, etc.

### ■ Care and maintenance of discs

If dirt or dust is attached to the playing surface of a disc, clean it carefully using a commercially-available CD cleaning cloth, etc.

When wiping the disc, be sure to wipe it in a radial direction. (Do not use a record cleaner for ordinary disks.)

Avoid leaving discs under direct sunlight or in a place where the temperature is high.

When a disc is not to be used for a long period of time, do not leave it in the CD player.

### ■ Battery life indicator

The CHARGE indicator  starts blinking at fast speed when the remaining battery life comes to around 30 minutes. In this case, replace the alkaline dry batteries with new ones or recharge the rechargeable batteries.

Refer to pages 6 and 7 for the method of replacing batteries or recharging batteries.

# In case of difficulty

What appears to be a malfunction may not always be serious. Firstly, check the following items before consulting the service personnel.

Symptom	Cause	Remedy
No operation occurs when an operation button is pressed.	<ul style="list-style-type: none"> <li>● The HOLD switch is set to ON.</li> <li>● The power is set to OFF.</li> <li>● The disc is placed upside down.</li> <li>● Dew is condensed inside the unit (refer to page 3).</li> <li>● The AC adapter is unplugged.</li> <li>● The batteries are exhausted.</li> </ul>	<ul style="list-style-type: none"> <li>● Set the HOLD switch to OFF.</li> <li>● Press the PLAY/PAUSE button to turn power ON.</li> <li>● Place the disc with the label side facing up.</li> <li>● Turn power OFF and wait for about an hour before operating the unit again.</li> <li>● Plug it properly.</li> <li>● Replace the alkaline dry batteries, or recharge the rechargeable batteries.</li> </ul>
Sound is not produced from the headphones.	<ul style="list-style-type: none"> <li>● The headphones plug is not inserted securely in the PHONES jack.</li> <li>● The VOLUME control is set to a too low position.</li> </ul>	<ul style="list-style-type: none"> <li>● Insert securely into the PHONES jack.</li> <li>● Increase the volume to a suitable level that does not annoy other people.</li> </ul>
Sound skips.	<ul style="list-style-type: none"> <li>● The laser lens is dirty.</li> <li>● The disc is dirty.</li> <li>● The unit is placed in a place subject to strong vibration of the car.</li> </ul>	<ul style="list-style-type: none"> <li>● Clean the lens.</li> <li>● Clean the disc.</li> <li>● Place it on the place less subject to vibrations, such as on the seat.</li> </ul>

- Abnormal operation may sometimes occur when the batteries are exhausted. In such a case, turn the power OFF (by pressing the stop button twice), and replace the alkaline dry batteries or recharge the rechargeable batteries.

**For the U.S.A.  
FCC WARNING:**

This equipment may generate or use radio frequency energy. Changes or modifications to this equipment may cause harmful interference unless the modifications are expressly approved in the instruction manual. The user could lose the authority to operate this equipment if an unauthorized change or modification is made.

**NOTE:**

This equipment has been tested and found to comply with the limits for a CLASS B digital device, pursuant to Part 15 of the FCC Rules. These limits are designed to provide reasonable protection against harmful interference in a residential installation. This equipment may cause harmful interference to radio communications, if it is not installed and used in accordance with the instructions. However, there is no guarantee that interference will not occur in a particular installation. If this equipment does cause harmful interference to radio or television reception, which can be determined by turning the equipment off and on, the user is encouraged to try to correct the interference by one or more of the following measures:

- — Reorient or relocate the receiving antenna.
- — Increase the separation between the equipment and receiver.
- — Connect the equipment into an outlet on a circuit different from that to which the receiver is connected.
- — Consult the dealer or an experienced radio/TV technician for help.

**For CANADA  
DOC REGULATION**

"This digital apparatus does not exceed the CLASS B limits for radio noise emissions from digital apparatus as set out in the radio interference regulations of the Canadian department of communications."

## Specifications

Tracking system .....	Three-beam tracking	
D/A converter .....	16 bit, linear	
Filter .....	Eight times oversampling digital filter	
Frequency response .....	20 to 20,000 Hz, $\pm 1$ dB	
Total harmonic distortion .....	0.04% (at 1 kHz)	
Output terminals .....	Headphone jack: 3.5 mm stereo mini-jack LINE OUT jack: 3.5 mm stere mini-jack	
Input terminal .....	DC IN (external power supply)	
Output level .....	12 mW + 12 mW (16 $\Omega$ , at 1 kHz)	
Line output .....	0.7 V (47 k $\Omega$ at 1 kHz)	
Power consumption .....	1.5 W	
Power requirement .....	6 V DC: provided rechargeable batteries 120 V AC 60 Hz (U.S.A. and CANADA, using the provided AC adaptor) 240 V AC 50 Hz (U.K. using the provided AC adaptor) 110 ~ 120 V/220 ~ 240 V AC 50 Hz/60 Hz (All other type, using the provided AC adaptor)	
Battery life .....	About 2 hours (continuous Repeat Play) (may vary depend on charging condition)	
Dimensions (W x H x D) .....	131 (W) x 37.5 (H) x 158 (D) mm	
Weight .....	370 g (without rechargeable battery)	
Accessories .....	Audio connection cord	x 1
(U.S.A. and CANADA Type)	AC adaptor	x 1
	Rechargeable battery (AA)	x 4
	Wireless remote controller (RC-P100)	x 1
	Car audio cassette adaptor (CAC-1)	x 1
Accessories .....	Audio connection cord	x 1
(U.K. and European Type)	AC adaptor	x 1
	Rechargeable battery (AA)	x 4
	Wireless remote controller (RC-P100)	x 1
Accessories .....	Audio connection cord	x 1
(All other type)	AC adaptor	x 1
	Rechargeable battery (AA)	x 4
	Wireless remote controller (RC-P100)	x 1
	Car audio cassette adaptor (CAC-1)	x 1
	Car battery adaptor	x 1
	Carrying case	x 1
	Headphones	x 1

KENWOOD follows a policy of continuous advancements in development. For this reason specification may be changed without notice.

KENWOOD